



®

# PAC100S-S

## PACKAGED AIR-COOLED 10 HP SINGLE CIRCUIT SEMI-HERMETIC

### DIMENSIONAL DRAWINGS

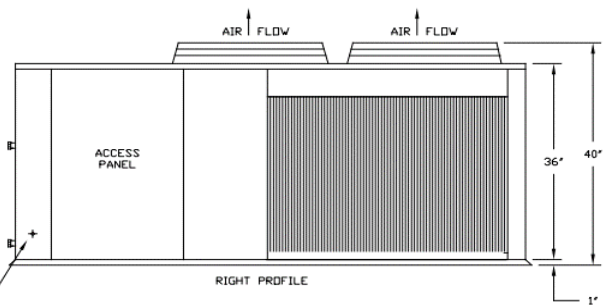
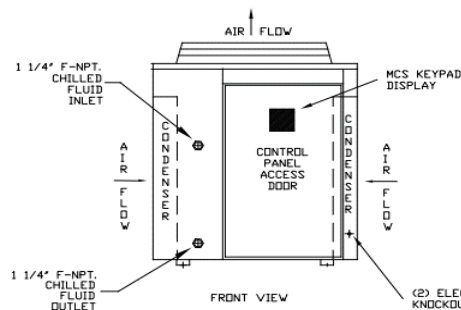
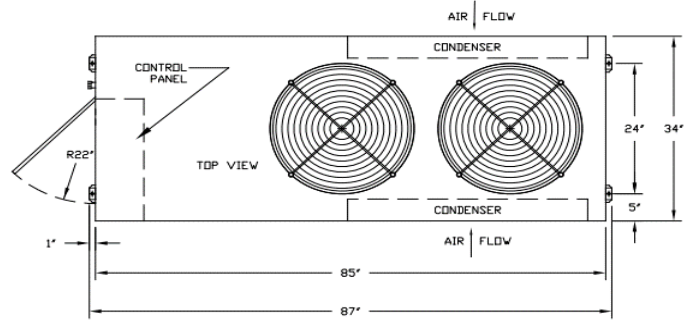
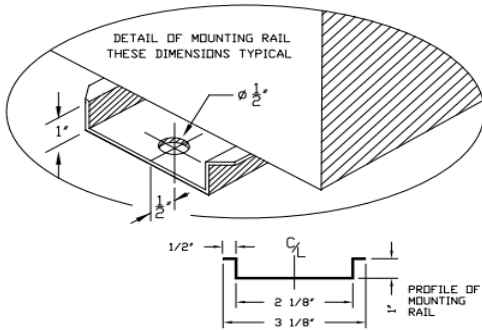

LENGTH	WIDTH	HEIGHT	WEIGHT	FLUID CONNECTIONS
87"	34"	40"	1000 LBS	1 1/4" F-NPT

### PRODUCT PERFORMANCE INFORMATION

REFRIGERANT	COMPRESSOR OPER. TEMP. SUCTION RANGE	LFT °F	80°F AMB		90°F AMB		95°F AMB		100°F AMB		105°F AMB	
			TONS	EER	TONS	EER	TONS	EER	TONS	EER	TONS	EER
R407C	10°F to 55°F	20	6.3	8.0	5.7	7.0	5.5	6.6	5.2	6.2	4.9	5.8
		35	8.5	9.5	7.9	8.4	7.6	7.9	7.3	7.4	7.0	7.0
		45	10.1	10.6	9.4	9.3	9.1	8.7	8.7	8.1	8.4	7.7
		55	11.8	11.8	11.0	10.2	10.6	9.5	10.2	8.8	9.8	8.3
		65	13.4	13.0	12.5	11.1	12.0	10.3	11.6	9.5	11.1	8.8
R404A	-10°F to 45°F	0	4.4	5.9	4.0	5.2	3.8	4.9	3.5	4.5	3.3	4.2
		10	5.6	6.8	5.0	6.0	4.8	5.6	4.6	5.2	4.3	4.9
		25	7.6	8.2	7.0	7.2	6.6	6.7	6.3	6.2	6.0	5.8
		40	9.9	9.5	9.0	8.2	8.6	7.7	8.2	7.2	7.8	6.7
		55	12.4	10.8	11.3	9.3	10.8	8.7	10.3	8.1	9.8	7.5

**DRAKE REFRIGERATION INC**  
 2900 SAMUEL DRIVE  
 BENSALEM, PA 19020  
 (888) 289-7299  
[www.drakechillers.com](http://www.drakechillers.com)

\*ALL INFORMATION **FOR REFERENCE ONLY**



# PAC100S-S

## PACKAGED AIR-COOLED 10 HP SINGLE CIRCUIT SEMI-HERMETIC

### STANDARD FEATURES

FEATURE	BENEFIT
Listings	ETL 3046941, UL STD 1995, CAN/CSA STD, C22.2 No. 236
Micro Control Systems Controller	Open source, microprocessor built to operate in the HVAC/R industry
Controls	BMS, BAS communications, remote access, monitoring services
Stainless Steel Brazed Plate Evaporator	Corrosion resistant, fully insulated and selected upon requirements
Copeland Semi-Hermetic Compressor	Industry leader, rebuildable, long lasting compressor
Variable Capacity Control	Allows for soft-start and stepped capacity control from 50-100%
Compressor Crankcase Heater	Prevents compressor damage caused by cold refrigerant on startup
Suction Accumulator	Protects the compressor from damage caused by liquid flood back by preventing liquid from entering the compressor
Water Flow Switch	Protects against process fluid freezing caused by pump failure
Copper Tube/Aluminum Fin Condenser	Rust resistant and high CFM
Compressor Vibration Eliminators	Eliminates vibration transfer and reduces noise
Painted Galvanized Steel Metal Cabinet	Sturdy, corrosion resistance, professional appearance
Insulated Process Fluid Lines	Maximum thermal efficiency
Factory Tested	Ensures the unit meets the customer's performance designed criteria and arrives in working order
Full Refrigerant Charge	Hassle free and more efficient installation
NEMA 3R Rated Electrical	Indoor/outdoor use
Phase Monitors	Electrical protection for compressors

### AVAILABLE OPTIONS

OPTIONS	AVAILABLE
Extended Warranty	4 year extended compressor warranty
Compressors	Equivalent compressors available from Bitzer and Carlyle
Electrical	Compressor fusing, disconnects, circuit breakers and more
Stainless Steel Pumps	1/3 HP to 25 HP on board pumps in multiple configurations & options
Fluid Piping Upgrades	Flow meters, pressure gauges, low flow bypass valves, and more
Coastal Protection/Hazardous Environments	Heresite coating, "Gold" and Copper condenser coils
Low Ambient Protection	EC fan for temperature down to +10°F, Head pressure control for temperatures down to -20°F, Heated receivers for temperature down to -40°F
Other	Casters, service outlets, city water add-ons, heaters, etc.

*More options and customization available, contact factory for information: (888) 289 - 7299*

### AVAILABLE MODEL NUMBER VOLTAGE REFERENCE

T3 (208-230/3/60) --- T4 (460/3/60) --- T5 (575/3/60)

### PRODUCT INFORMATION

MODELS AVAILABLE	COMPRESSOR			FAN MOTOR		RLA EA	LRA EA	MCA	MOP	RECIRC. TANK
	MODEL	QTY	HP	QTY	FLA EA					
R407C R404A										
PAC100S3-T3-S	3DPHR12ME	1	10	2	3.3	43.6	215	60	100	N/A
PAC100S3-T4-S					1.6	20	106	30	45	
PAC100S3-T5-S					1.9	16.5	84	25	40	
PAC100S6-T3-S	3DPHR12ME	1	10	2	3.3	43.6	215	70	100	N/A
PAC100S6-T4-S					1.6	20	106	30	45	
PAC100S6-T5-S					1.9	16.5	84	25	40	

**DRAKE REFRIGERATION INC**  
 2900 SAMUEL DRIVE  
 BENSALEM, PA 19020  
 (888) 289-7299  
[www.drakechillers.com](http://www.drakechillers.com)

\*ALL INFORMATION **FOR REFERENCE ONLY**