



®

PWC1020Q-Z

PACKAGED WATER-COOLED 100 HP TANDEM SCROLL

DIMENSIONAL DRAWINGS

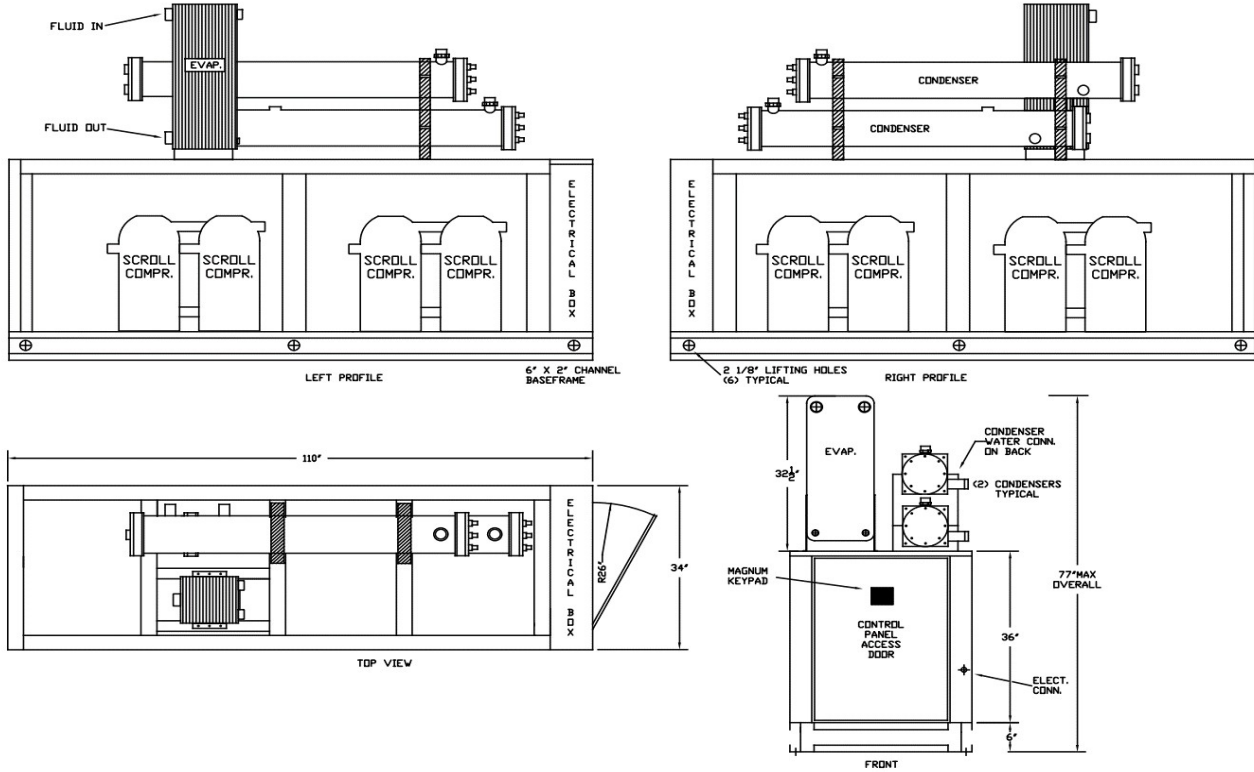

LENGTH	WIDTH	HEIGHT	WEIGHT	FLUID CONNECTIONS
110"	34"	42" - 77" MAX	4700 lbs	3" F-NPT

PRODUCT PERFORMANCE INFORMATION

REFRIGERANT	COMPRESSOR OPER. SUCTION TEMP. RANGE	LFT °F	75 °F ECFT		80 °F ECFT		85 °F ECFT		90 °F ECFT		95 °F ECFT	
			TONS	KBTU/H	TONS	KBTU/H	TONS	KBTU/H	TONS	KBTU/H	TONS	KBTU/H
R407C	10°F to 55°F	20	54.8	658	53.3	640	51.8	621	50.2	602	48.5	582
		35	77.5	930	75.5	906	73.4	881	71.3	856	69.2	830
		45	96.5	1158	94.0	1128	91.4	1097	88.9	1066	86.3	1035
		55	119.2	1430	116.1	1393	113.0	1356	109.9	1318	106.7	1280
		60	132.1	1586	128.7	1544	125.2	1503	121.8	1462	118.3	1420

DRAKE REFRIGERATION INC
 2900 SAMUEL DRIVE
 BENSLEM, PA 19020
 (888) 289-7299
www.drakechillers.com

*ECFT- Entering Condenser Fluid Temperature
 *ALL INFORMATION **FOR REFERENCE ONLY**



®

PWC1020Q-Z

PACKAGED WATER-COOLED 100 HP TANDEM SCROLL

STANDARD FEATURES

FEATURE	BENEFIT
Listings	ETL 3046941, UL STD 1995, CAN/CSA STD, C22.2 No. 236
Micro Control Systems Controller	Open source, microprocessor built to operate in the HVAC/R industry
Controls	BMS, BAS communications, remote access, monitoring services
Stainless Steel Brazed Plate Evaporator	Corrosion resistant, fully insulated and selected upon requirements
Copeland Tandem Scroll Compressors	Industry leader, long lasting compressor
25%-100% Capacity Control	Allows for tight control on varying loads
Compressor Crankcase Heater	Prevents compressor damage caused by cold refrigerant on startup
Suction Accumulator	Protects the compressor from damage caused by liquid flood back by preventing liquid from entering the compressor
Water Flow Switch	Protects against process fluid freezing caused by pump failure
Hot Gas Bypass	Aids in the prevention of evaporator freeze ups and capacity control
Copper Tube Condenser Barrel	Corrosion resistant and cleanable, enhanced heat transfer
Compressor Vibration Eliminators	Eliminates vibration transfer and reduces noise
Painted Galvanized Steel Metal Cabinet	Sturdy, corrosion resistance, professional appearance
Insulated Process Fluid Lines	Maximum thermal efficiency
Factory Tested	Ensures the unit meets the customer's performance designed criteria and arrives in working order
Full Refrigerant Charge	Hassle free and more efficient installation
NEMA 3R Rated Electrical	Indoor/outdoor use
Phase Monitors	Electrical protection for compressors

AVAILABLE OPTIONS

OPTIONS	AVAILABLE
Extended Warranty	4 year extended compressor warranty
Electronic Expansion Valves	Added consistency, efficiency, and control
Electrical	Compressor fusing, disconnects, circuit breakers and more
Stainless Steel Pumps	1/3 HP to 25 HP on board pumps in multiple configurations & options
Fluid Piping Upgrades	Flow meters, pressure gauges, low flow bypass valves, and more
Chiller Evaporator Barrel	Enhanced corrosion resistance and cleanable, fully insulated, extra capacity
Marine Condenser	For corrosion resistance and saltwater applications
Head Pressure Control	Condenser water regulating valves
Other	Service outlets, city water add-ons, heaters, etc.

More options and customization available, contact factory for information: (888) 289 - 7299

AVAILABLE MODEL NUMBER VOLTAGE REFERENCE

T3 (208-230/3/60) --- T4 (460/3/60) --- T5 (575/3/60)

PRODUCT INFORMATION

MODELS AVAILABLE	COMPRESSOR			RLA EA	LRA EA	CONDENSER		MCA	MOP	RECIRC. TANK
	MODEL	QTY	HP			TYPE	CONNECTIONS			
R407C										
PWC1020Q3-T3-Z	ZR300KCE	4	25 EA	100	500	BARREL	4" F-NPT	425	525	N/A
PWC1020Q3-T4-Z				48.6	250			210	255	
PWC1020Q3-T5-Z				36.4	198			155	190	

DRAKE REFRIGERATION INC
 2900 SAMUEL DRIVE
 BENSLEM, PA 19020
 (888) 289-7299
www.drakechillers.com

*ALL INFORMATION **FOR REFERENCE ONLY**