



®

FPACT100S

FRACTIONAL LINE PACKAGED AIR-COOLED 1 HP SINGLE CIRCUIT HERMETIC WITH TANK

DIMENSIONAL DRAWINGS

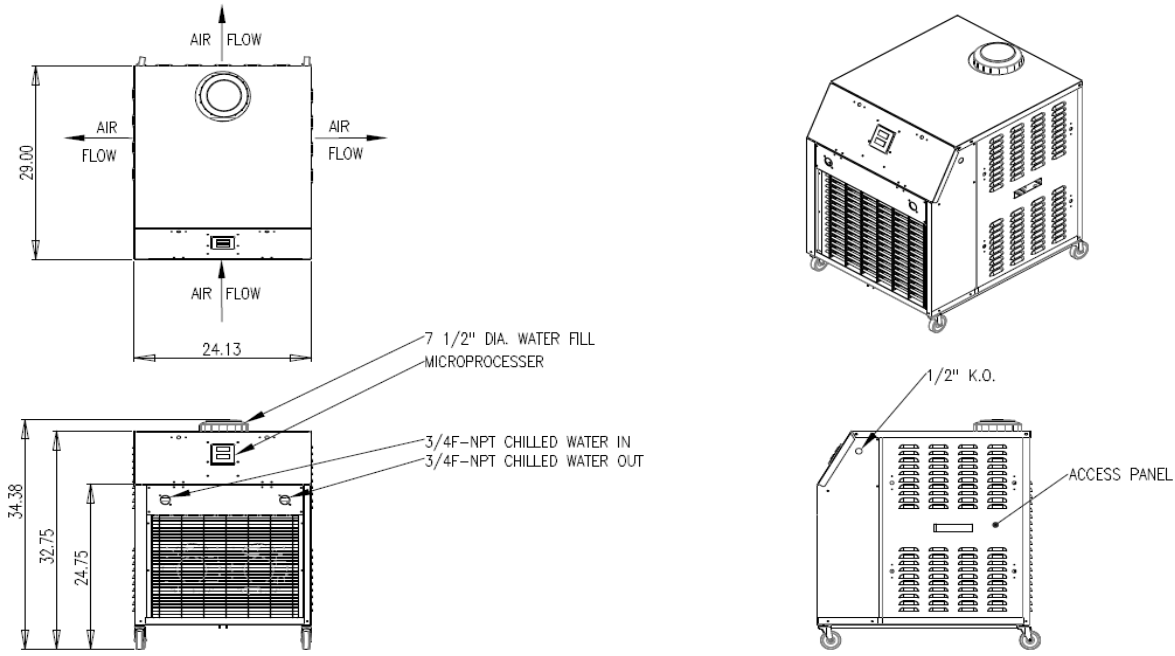

LENGTH	WIDTH	HEIGHT	FLUID CONNECTIONS	TANK CAPACITY	WEIGHT
29"	24.25"	34.5"	3/4 F-NPT	2.5 GAL	175 LBS

PRODUCT PERFORMANCE INFORMATION

REFRIGERANT	COMPRESSOR OPER. TEMP. SUCTION RANGE	LFT °F	80°F AMB		90°F AMB		95°F AMB		100°F AMB		105°F AMB	
			BTUH	EER	BTUH	EER	BTUH	EER	BTUH	EER	BTUH	EER
R134A	5°F to 50°F	15	4321	4.8	3944	4.4	3756	4.1	3567	3.9	3380	3.7
		20	5184	5.5	4690	4.9	4448	4.6	4215	4.4	3973	4.1
		30	7095	6.6	6427	5.9	6068	5.5	5749	5.2	5410	4.9
		40	9416	7.7	8540	6.8	8181	6.5	7770	6.1	7308	5.7
		50	11908	8.6	10881	7.7	10396	7.2	9998	6.9	9447	6.5
		60	14634	9.5	13562	8.6	13028	8.1	12414	7.7	11965	7.3

DRAKE REFRIGERATION INC
 2900 SAMUEL DRIVE
 BENSLEM, PA 19020
 (888) 289-7299
www.drakechillers.com

*ALL INFORMATION **FOR REFERENCE ONLY**



®

FPACT100S

FRACTIONAL LINE PACKAGED AIR-COOLED 1 HP SINGLE CIRCUIT HERMETIC WITH TANK

STANDARD FEATURES	
FEATURE	BENEFIT
Listings	ETL 3046941, UL STD 1995, CAN/CSA STD, C22.2 No. 236
Microprocessor Control	Stand alone, simple, accurate control with over 10 years of field testing
Stainless Steel Brazed Plate Evaporator	Corrosion resistant evaporator wrapped in closed cell insulation
Hermetic Compressor	Industry leader, long lasting compressor with motor contactor
Reservoir Tank	Insulated polyethylene storage tank for increased process volume
Stainless Steel Pump	Fused, non-ferrous pump for process circulation
Copper Tube/Aluminum Fin Condenser	Rust resistant and high CFM
Painted Galvanized Steel Metal Cabinet	Sturdy, corrosion resistance, professional appearance
Polyethylene Storage Tank	Closed cell insulation for increase temperature control with reliable, corrosion resistant
Insulated Process Fluid Lines	Maximum thermal efficiency
Factory Tested	Ensures the unit meets the customer's performance designed criteria and arrives in working order
Full Refrigerant Charge	Hassle free and more efficient installation
NEMA 3R Rated Electrical	Indoor/outdoor use

Customization available, contact factory for information: (888) 289 - 7299

AVAILABLE MODEL NUMBER VOLTAGE REFERENCE
S1 (115/1/60) --- S2 (208-230/1/60)

PRODUCT INFORMATION											
MODELS AVAILABLE	COMPRESSOR			FAN MOTOR		CHILLER PUMP		RLA EA	LRA EA	MCA	MOP
	MODEL	QTY	HP	QTY	FLA EA	HP	FLA				
R134A											
FPACT100S1-S1-H	RR10K2E	1	1	2	0.81	1/3	4.4	16.9	78	30	40
FPACT100S1-S2-H					0.43		1.8				

DRAKE REFRIGERATION INC
 2900 SAMUEL DRIVE
 BENSLEM, PA 19020
 (888) 289-7299
www.drakechillers.com

*ALL INFORMATION **FOR REFERENCE ONLY**