



®

ES50S

SPLIT-SYSTEM AIR-COOLED 5 HP SINGLE CIRCUIT SCROLL

DIMENSIONAL DRAWINGS

EVAPORATOR SECTION - ES50S

DETAIL OF MOUNTING RAIL
THESE DIMENSIONS TYPICAL

$\phi \frac{1}{2}''$

1"

$\frac{1}{2}''$

2 $\frac{1}{8}''$

3 $\frac{1}{8}''$

1"

PROFILE OF MOUNTING RAIL

TOP VIEW

44"

46"

28"

R22"

1"

DISCHARGE LINE

LIQUID LINE

1/2" MOUNTING HOLES (4) TYPICAL

LOUVERED ACCESS PANEL

LEFT PROFILE

MCS KEYPAD DISPLAY

PROCESS FLUID INLET

PROCESS FLUID OUTLET

CONTROL PANEL ACCESS DOOR

26"

27"

(4) ELECTRIC CONNECTION KNOCKOUTS THIS CORNER

5"

18"

1"

FRONT

LENGTH	WIDTH	HEIGHT	WEIGHT	FLUID CONNECTIONS	REFRIGERANT CONNECTIONS	
					DISCHG	LIQUID
28"	46"	27"	575 LBS	1" F-NPT	3/4"	1/2"

PRODUCT PERFORMANCE INFORMATION

REFRIGERANT	COMPRESSOR OPER. SUCTION TEMP. RANGE	LFT °F	80°F AMB		90°F AMB		95°F AMB		100°F AMB		105°F AMB	
			TONS	EER	TONS	EER	TONS	EER	TONS	EER	TONS	EER
R407C	25°F to 55°F	35	4.0	9.4	3.8	8.2	3.7	7.6	3.6	7.1	3.5	6.6
		45	4.8	11.2	4.6	9.8	4.5	9.1	4.4	8.6	4.3	8.0
		55	5.7	13.1	5.5	11.5	5.4	10.8	5.3	10.1	5.1	9.4
		65	6.8	15.1	6.5	13.4	6.4	12.5	6.2	11.7	6.1	11.0
R404A	-10°F to 45°F	0	2.4	5.9	2.1	4.8	2.0	4.2	1.9	3.8	1.8	3.4
		10	3.0	7.1	2.7	5.8	2.6	5.3	2.4	4.7	2.3	4.2
		25	4.0	9.2	3.7	7.7	3.5	6.9	3.3	6.3	3.2	5.6
		40	5.2	11.5	4.8	9.6	4.6	8.8	4.4	8.0	4.2	7.2
		55	6.5	13.8	6.0	11.6	5.8	10.6	5.5	9.7	5.3	8.8

DRAKE REFRIGERATION INC
 2900 SAMUEL DRIVE
 BENSLEM, PA 19020
 (888) 289-7299
www.drakechillers.com

*ALL INFORMATION FOR REFERENCE ONLY



®

ES50S

SPLIT-SYSTEM AIR-COOLED 5 HP SINGLE CIRCUIT SCROLL

DIMENSIONAL DRAWINGS CONDENSER SECTION - CS50S

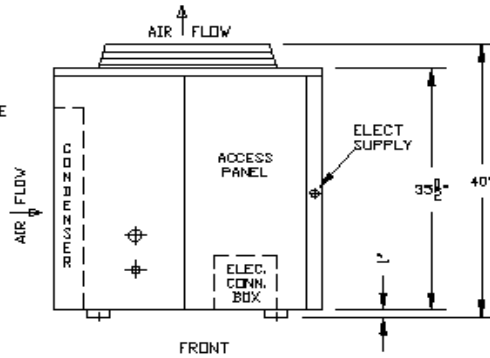
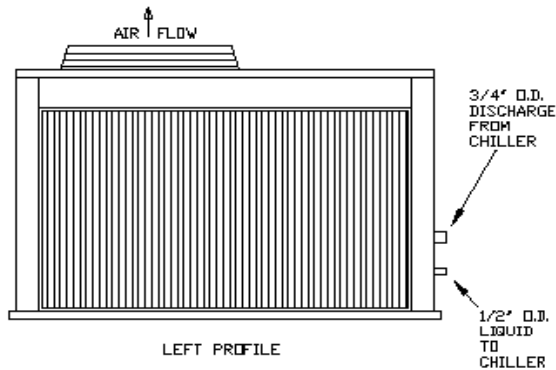
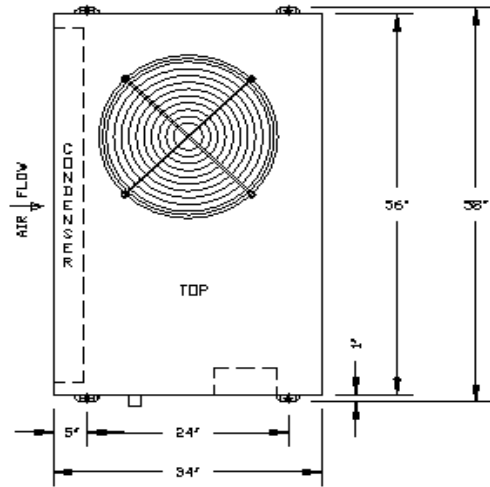
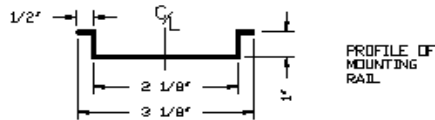
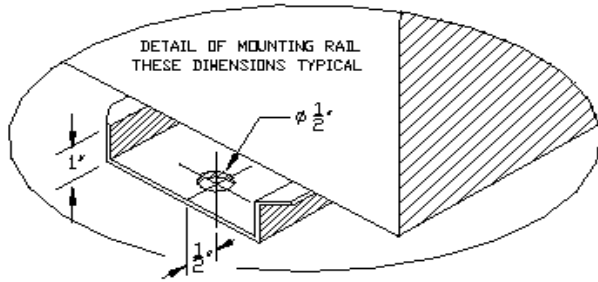

LENGTH	WIDTH	HEIGHT	WEIGHT	REFRIGERANT CONNECTIONS	
				DISCHG	LIQUID
34"	58"	40"	255 LBS	3/4"	1/2"

DRAKE REFRIGERATION INC

2900 SAMUEL DRIVE
BENSALEM, PA 19020
(888) 289-7299

www.drakechillers.com

*ALL INFORMATION **FOR REFERENCE ONLY**



ES50S

SPLIT-SYSTEM AIR-COOLED 5 HP SINGLE CIRCUIT SCROLL

STANDARD FEATURES	
FEATURE	BENEFIT
Listings	ETL 3046941, UL STD 1995, CAN/CSA STD, C22.2 No. 236
Micro Control Systems Controller	Open source, microprocessor built to operate in the HVAC/R industry
Controls	BMS, BAS communications, remote access, monitoring services
Stainless Steel Brazed Plate Evaporator	Corrosion resistant, fully insulated and selected upon requirements
Copeland Scroll Compressor	Industry leader, long lasting compressor
Compressor Crankcase Heater	Prevents compressor damage caused by liquid refrigerant on startup
Suction Accumulator	Protects the compressor from damage caused by liquid flood back by preventing liquid from entering the compressor
Water Flow Switch	Protects against process fluid freezing caused by pump failure
Hot Gas Bypass	Aids in the prevention of evaporator freeze ups and capacity control
Copper Tube/Aluminum Fin Condenser	Rust resistant and high CFM
Painted Galvanized Steel Metal Cabinet	Sturdy, corrosion resistance, professional appearance
Insulated Process Fluid Lines	Maximum thermal efficiency
Factory Tested	Ensures the unit meets the customer's performance designed criteria and arrives in working order
Full Refrigerant Charge	Hassle free and more efficient installation
NEMA 3R Rated Electrical	Indoor/outdoor use
Phase Monitors	Electrical protection for compressors

AVAILABLE OPTIONS	
OPTIONS	AVAILABLE
Extended Warranty	4 year extended compressor warranty
Electrical	Compressor fusing, disconnects, circuit breakers and more
Stainless Steel Pumps	1/3 HP to 25 HP on board pumps in multiple configurations & options
Fluid Piping Upgrades	Flow meters, pressure gauges, low flow bypass valves, and more
Coastal Protection/Hazardous Environments	Heresite coating, "Gold" and Copper condenser coils
Low Ambient Protection	EC fan for temperature down to +10°F, Head pressure control for temperatures down to 20°F, Heated receivers for temperature down to -40°F
Other	Casters, service outlets, city water add-ons, heaters, etc.

More options and customization available, contact factory for information: (888) 289 - 7299

AVAILABLE MODEL NUMBER VOLTAGE REFERENCE

S2 (208-230/1/60)

PRODUCT INFORMATION											
MODELS AVAILABLE		COMPRESSOR			FAN MOTOR		RLA EA	LRA EA	MCA	MOP	RECIRC. TANK
R407C	R404A	MODEL	QTY	HP	QTY	FLA EA					
ES50S3-S2-Z		ZB42KCE	1	5	1	3.3	27.9	129	40	65	N/A
ES50S6-S2-Z		ZB42KCE	1	5	1	3.3	31.4	129	45	70	N/A

DRAKE REFRIGERATION INC
 2900 SAMUEL DRIVE
 BENSALEM, PA 19020
 (888) 289-7299
www.drakechillers.com

*ALL INFORMATION **FOR REFERENCE ONLY**