



®

# ES370Q-Z

## SPLIT SYSTEM AIR-COOLED 36 HP DUAL-CIRCUIT TANDEM SCROLL

### DIMENSIONAL DRAWINGS

#### EVAPORATOR SECTION - ES370Q

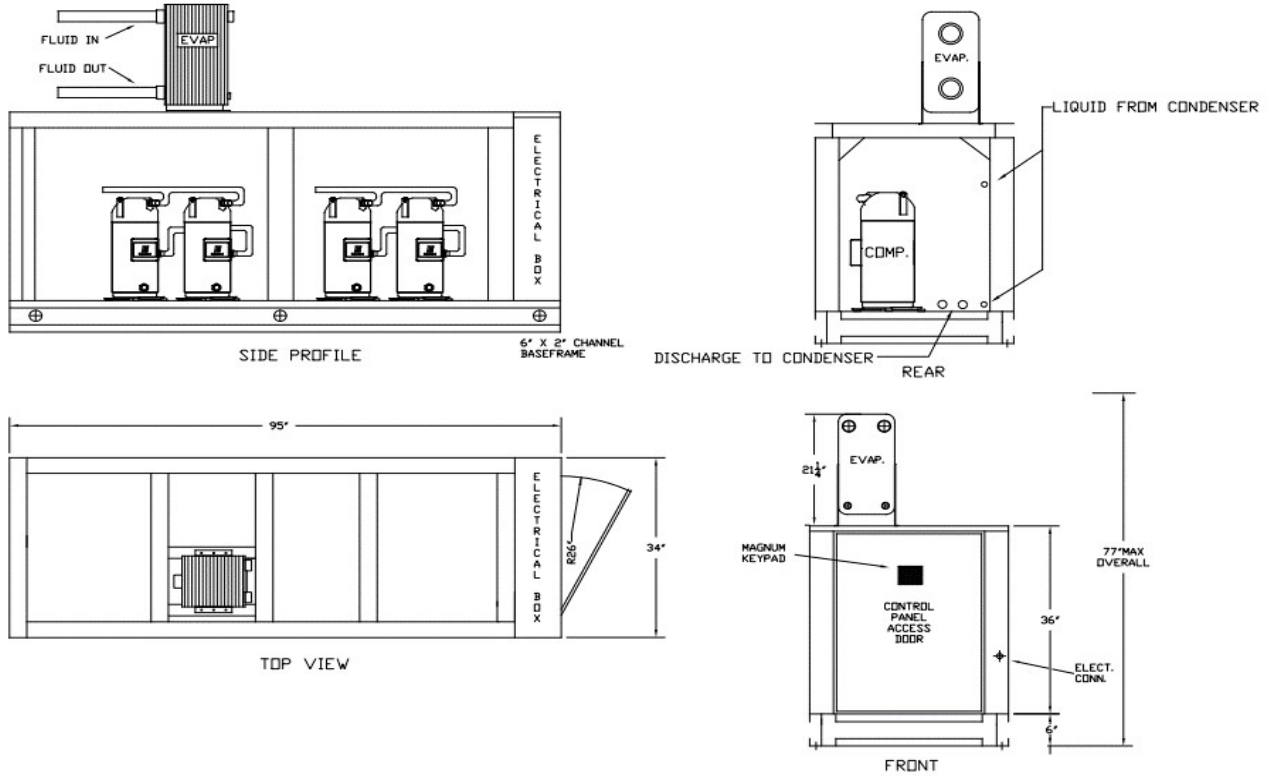

LENGTH	WIDTH	HEIGHT	WEIGHT	FLUID CONNECTIONS	R407C CONNECTIONS	
					DISCHG	LIQUID
95"	34"	77" MAX	2200	2" F-NPT	1 3/8"	7/8"

### PRODUCT PERFORMANCE INFORMATION

REFRIGERANT	COMPRESSOR OPER. SUCTION TEMP. RANGE	LFT °F	70 °F AMB		85 °F AMB		95 °F AMB		100 °F AMB		105 °F AMB	
			TONS	KBTU/H	TONS	KBTU/H	TONS	KBTU/H	TONS	KBTU/H	TONS	KBTU/H
R407C	10°F to 55°F	20	20.2	242	18.4	221	17.1	205	16.4	197	15.7	188
		35	28.7	344	26.4	317	24.8	298	23.9	287	23.0	277
		45	35.7	428	33.1	397	31.2	374	30.2	362	29.1	349
		55	43.9	527	40.9	491	38.7	464	37.5	450	36.3	435
		60	48.5	582	45.3	543	42.9	514	41.6	499	40.3	484

DRAKE REFRIGERATION INC

2900 SAMUEL DRIVE  
BENSALEM, PA 19020  
(888) 289-7299

[www.drakechillers.com](http://www.drakechillers.com)

\*ALL INFORMATION FOR REFERENCE ONLY



®

# ES370Q-Z

## SPLIT SYSTEM AIR-COOLED 36 HP DUAL-CIRCUIT TANDEM SCROLL

### DIMENSIONAL DRAWINGS

#### CONDENSER SECTION - CS370Q

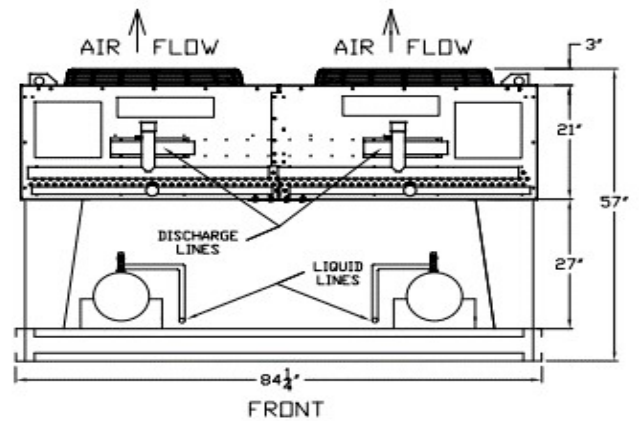
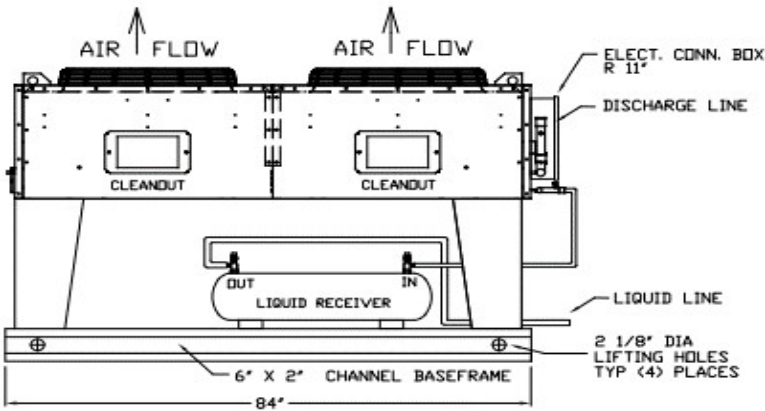
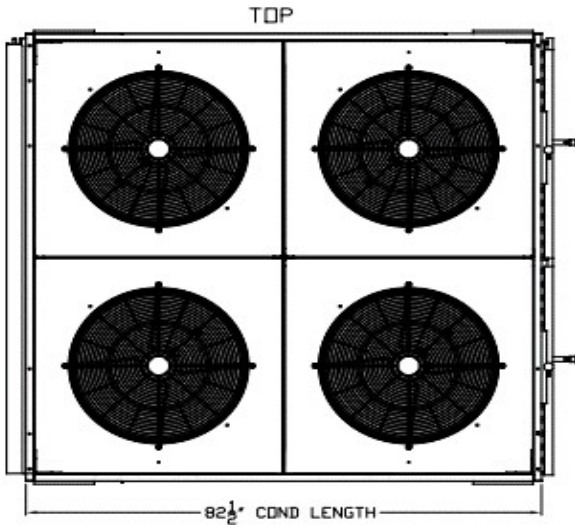

LENGTH	WIDTH	HEIGHT	WEIGHT	R407C CONNECTIONS	
				DISCHG	LIQUID
90" MAX	84.25"	57"	1450 LBS	1-3/8"	7/8"

**DRAKE REFRIGERATION INC**

2900 SAMUEL DRIVE  
 BENSALAM, PA 19020  
 (888) 289-7299

[www.drakechillers.com](http://www.drakechillers.com)

\*ALL INFORMATION *FOR REFERENCE ONLY*



# ES370Q-Z

## SPLIT SYSTEM AIR-COOLED 36 HP DUAL-CIRCUIT TANDEM SCROLL

### STANDARD FEATURES

FEATURE	BENEFIT
Listings	ETL 3046941, UL STD 1995, CAN/CSA STD, C22.2 No. 236
Micro Control Systems Controller	Open source, microprocessor built to operate in the HVAC/R industry
Controls	BMS, BAS communications, remote access, monitoring services
Stainless Steel Brazed Plate Evaporator	Corrosion resistant, fully insulated and selected upon requirements
Copeland Tandem Scroll Compressors	Industry leader, long lasting compressor
25%-100% Capacity Control	Allows for tight control on varying loads
Compressor Crankcase Heater	Prevents compressor damage caused by cold refrigerant on startup
Suction Accumulator	Protects the compressor from damage caused by liquid flood back by preventing liquid from entering the compressor
Water Flow Switch	Protects against process fluid freezing caused by pump failure
Hot Gas Bypass	Aids in the prevention of evaporator freeze ups and capacity control
Copper Tube/Aluminum Fin Condenser	Rust resistant and high CFM
Compressor Vibration Eliminators	Eliminates vibration transfer and reduces noise
Painted Galvanized Steel Metal Cabinet	Sturdy, corrosion resistance, professional appearance
Insulated Process Fluid Lines	Maximum thermal efficiency
Factory Tested	Ensures the unit meets the customer's performance designed criteria and arrives in working order
Full Refrigerant Charge	Hassle free and more efficient installation
NEMA 3R Rated Electrical	Indoor/outdoor use
Phase Monitors	Electrical protection for compressors

### AVAILABLE OPTIONS

OPTIONS	AVAILABLE
Extended Warranty	4 year extended compressor warranty
Electronic Expansion Valves	Added consistency, efficiency, and control
Electrical	Compressor fusing, disconnects, circuit breakers and more
Stainless Steel Pumps	1/3 HP to 25 HP on board pumps in multiple configurations & options
Fluid Piping Upgrades	Flow meters, pressure gauges, low flow bypass valves, and more
Chiller Evaporator Barrel	Enhanced corrosion resistance and cleanable, fully insulated, extra capacity
Coastal Protection/Hazardous Environments	Heresite coating, "Gold" and Copper condenser coils
Low Ambient Protection	EC fan for temperature down to +10°F, Head pressure control for temperatures down to 20°F, Heated receivers for temperature down to -40°F
Other	Service outlets, city water add-ons, heaters, etc.

*More options and customization available, contact factory for information: (888) 289 - 7299*

### AVAILABLE MODEL NUMBER VOLTAGE REFERENCE

T3 (208-230/3/60) --- T4 (460/3/60) --- T5 (575/3/60)

### PRODUCT INFORMATION

MODELS AVAILABLE	COMPRESSOR			RLA EA	LRA EA	FAN MOTOR		MCA	MOP	RECIRC. TANK
	MODEL	QTY	HP			QTY	FLA EA			
R407C										
ES370Q3-T3-Z	ZR108KCE	4	9 EA	33.6	225	4	2.3	155	185	N/A
ES370Q3-T4-Z				17.3	114		1.2	75	90	
ES370Q3-T5-Z				13.5	80		0.9	60	70	

**DRAKE REFRIGERATION INC**  
 2900 SAMUEL DRIVE  
 BENSLEM, PA 19020  
 (888) 289-7299  
[www.drakechillers.com](http://www.drakechillers.com)

\*ALL INFORMATION **FOR REFERENCE ONLY**